

	Part	Part. no.
1	Anti-slip protector	WG1000
2	Anti-slip protector, gutter	GS2815

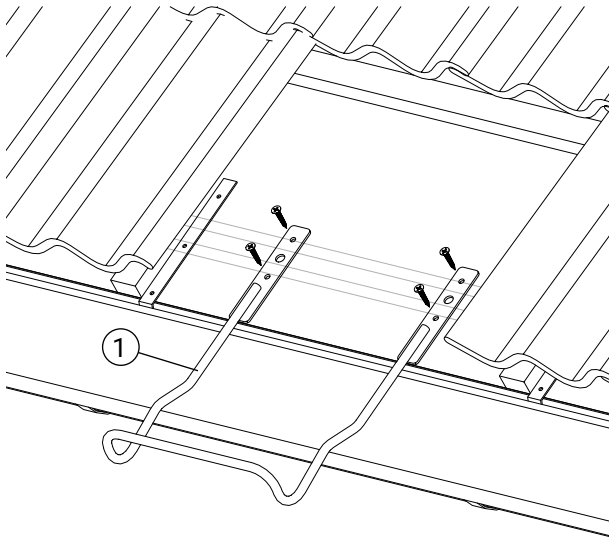

Installation of anti-slip protection using wood screw
Fasteners: 4 x Ø5x25mm wood screws for grooved board.

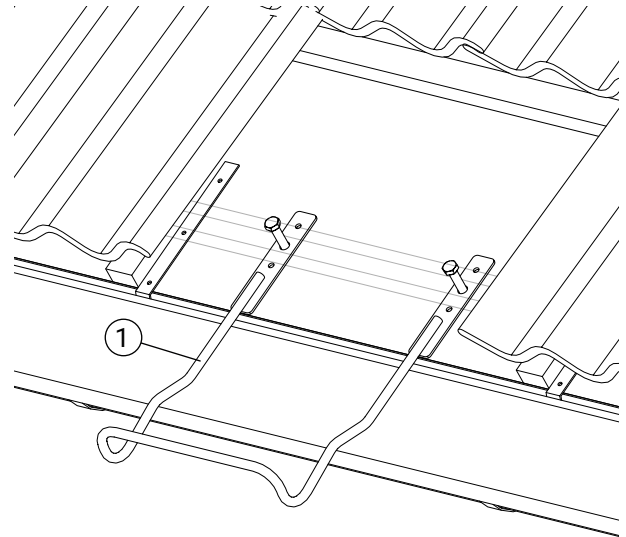

Installation of anti-slip protection with through bolt
Through bolt on grooved board.
Fasteners: 2 x M10 + nuts with washer.

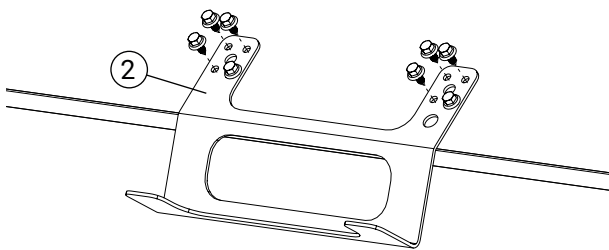

Installation of anti-slip protection directly on roof
Direct installation on roof
Fasteners: At least 8 x ≥ Ø5x25mm screws.

Installation material

Fixings (bolts, nuts, screws) must be of corrosion class C3 and be approved for 15 years of use. SE-EN ISO 12944-2. Fasteners that are built in or concealed shall be corrosion class C4 with a service life of 15 years or better. SE-EN ISO 12944-2.